

2126BK

NAPLES 3-LIGHT HANGING LANTERN

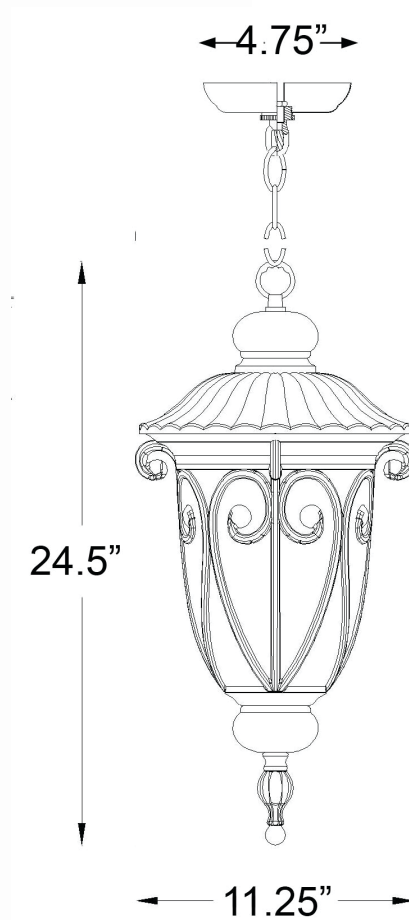

Description:	Naples 3-light hanging lantern
Finish:	Matte black
Dimensions:	11-1/4" W x 24-1/2" H
Bulbs:	3-60w cand.
Installed Weight:	10 lbs.
Certification:	Damp location

Material:	Cast aluminum
Shade:	Glass
Glass:	Clear seeded
Canopy Dimensions:	4-3/4" dia.
Chain/Wire:	5' chain, 10' wire
Additional Finishes:	Marbleized mahogany